



SHANXI MIDAS PIPELINE

Shanxi Midas Industrial Co.,LTD.

**Ductile Iron Pipe**

PIPELINE SPECIALIST

## Company Profile

Shanxi Midas Industrial Co., Ltd ( Briefly called: MDS ) is located in the heavy industry province of Shanxi, China with rich resources of pig iron, coke, steel and other industrial raw materials. MDS is a professional supplier mainly supplying ductile iron pipes and pipe fittings, it can supply annually 150000 tons ductile iron pipes from DN80 to DN1800 and 16000 tons ductile iron pipe fittings of over forty kinds and more than three thousand specifications from DN80 to DN2000 that are widely used in drinkable water, sewage, irrigation, gas, oil pipeline, as well as food, pharmaceutical and chemical industry production process pipe network.

MIDAS product is complying with international standards, i.e.ISO2531, EN545 and EN598 and can provide customized product as per customer request.

We are eager to get your inquiries and establish long term mutual benefit cooperation relationship with you. We have our advantage in manufacturing and you have your advantages in sales, we are sure with our working together we can get one "win-win" situation.We hope we can grow together!



**ISO2531 EN598**  
**EN545 BS4772**

## Ductile iron material

In so called "grey irons" the graphite is present in the form of flakes, hence their metallurgical name: flake graphite irons (sometimes called lamellar graphite irons), by concentrating abnormal stresses at certain points, each of these flakes may initiate cracking.

Metallurgists have therefore sought to diminish, or eliminate this effect by changing the size or distribution of the flakes. In a first stage, the adoption of the centrifugal process to cast flake graphite iron pipes (so called grey iron pipes), led to an appreciable improvement by producing very fine graphite flakes.

A decisive advance was then made in 1948, when research in both the USA and Great Britain led to the discovery of spheroidal graphite iron, more commonly known as ductile iron. In ductile iron, the graphite exists in the form of spheroidal shape, which has little influence on weakening the matrix and resulting in centralizing strain, so ductile iron possesses good flexible property. While in grey iron, the graphite is present in flake form, which has the effect of cutting the iron matrix and making it become brittle and easy to crack.

Graphite precipitation in spheroidal form is obtained by the controlled addition of a small amount of magnesium to the previously desulfurized base iron.

Ductile iron owes its remarkable mechanical properties to the spheroidal shape of its graphite:

- tensile strength
- impact resistance
- high elastic limit (yield strength)
- good elongation

These properties are further enhanced by control of the chemical analysis and heat treatment of the metal matrix.

Ductile iron maintains the traditional qualities of cast irons, resulting from the high carbon content:

- compression strength
- castability
- abrasion resistance
- machinability
- fatigue strength

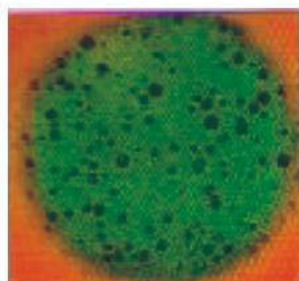

Ductile iron metallography



Grey iron metallography

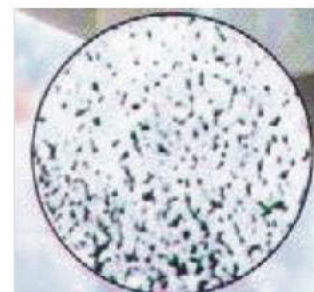

Steel pipe metallography



## **General ductile iron pipes**

### **For potable water**

ISO9001 Quality systems – model for quality assurance in design development production, installation and servicing.

ISO 2531 Ductile iron pipes, fittings and accessories for pressure pipelines.

BS EN545 Ductile iron pipes, fittings and accessories and their joints for water pipelines. Requirements and test methods.

ISO4179 Ductile iron pipes for pressure and non pressure pipelines–Centrifugal cement mortar lining–general requirements.

ISO8179 Ductile iron pipes–External zinc coating.

BS3416 Specification for Bitumen based coatings for cold application, suitable for use in contact with potable water.

ISO4633 Rubber Seals –joint rings for water supply, drainage and sewerage pipelines specs for materials.

ISO 8180 Ductile iron pipes –Polyethylene Sleeving.

EN681–1 Elastomeric seals material requirements for pipe joint seals used in water and drainage application.

### **For sewage application**

BS EN598 Ductile iron pipes, fittings, accessories and their joints for sewage application requirements and test methods.

ISO4633 Rubber seals–joint rings for water supply, drainage and sewerage pipelines specs for materials.

EN681–1 Elastomeric seals material requirements for pipe joint seals used in water and drainage application.

All MIDAS pipes are manufactured complying with standards:

- ISO2531
- EN545
- EN598

Ductile iron pipes whose materials are ductile cast iron have adopted the technology of centrifugal casting, and are widely used in various pipeline projects on metallurgy, mine, water conservancy, petroleum and urban public facilities to convey many fluid media such as water and gas. Ductile iron pipes possess the nature of iron and the performance of steel and have characteristics of high strength, high elongation and corrosion resistance, which is the best choice in today's world for conveying water and gas safely and reliably, they are the substitutes for traditional cast iron pipes and common steel pipes. In addition, ductile iron pipes are produced with high straightness, high surface finish, high size accuracy, even wall thickness, fine mechanical properties and hard external coating. Flexible push-on joint and rubber gasket are used to result in a convenient installation of pipes.

## Ductile iron pipe mechanical properties

	Ductile iron pipe	Grey Cast Iron Pipe	Steel Pipe
Tensile strength(N/mm <sup>2</sup> )	≥420	150-260	≥400
Yield strength(N/mm <sup>2</sup> )	300	——	——
Bending strength(N/mm <sup>2</sup> )	Min.590	200-360	Min.400
Elongation(%)	DN80-1000≥10 DN1200-2200≥7	Negligible	Min.18
Module of Elasticity(N/mm <sup>2</sup> )	Approx. 16 x 10 <sup>4</sup>	Approx. 11 x 10 <sup>4</sup>	Approx. 16 x 10 <sup>4</sup>
Hardness (HB)	≤230	≤230	Approx.140

DN( mm )	Hydro Test Pressure for K9 pipe, Mpa
80-300	5.0
350-600	4.0
700-1000	3.2
1100-2000	2.5
2200-2600	2.0

Document relevant to earthquakes shows that the damage rate per kilometer for ductile iron pipe mains is one quarter of that for grey iron and one thirtieth of some other materials of pipes.

Pipe material	Damage rate per km of main pipeline in earthquake
Ductile iron pipe	0.04
Grey cast pipe	0.17
PVC pipe	0.14
Steel pipe	1.24



Flat-pressing test



Ring pressed test

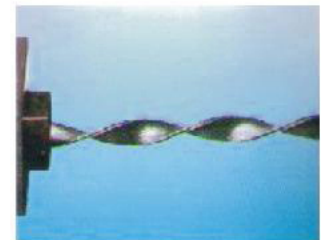

Twist test



Elongation test



Damage test



Hardness test

## Chemical analysis



## Corrosion resistance properties

	Corrosion in running water at 90 days(G/cm <sup>2</sup> )	Corrosion in sea water (Mm/a)	Corrosion in 72h 5% hydrochloric Acid Liquor (G/cm <sup>2</sup> )	100℃ 33% Corrosion in Vitriol Liquor(mg/cm <sup>2</sup> .h)
Ductile iron pipe	0.009	0.066	0.0821	620
Grey Cast Iron Pipe	0.0103	0.073	0.6899	470
Steel Pipe	0.0396	0.13	≥ 10	250

## Chemical composition

Chemical composition	Ductile Iron Pipe(%)	Steel Pipe(%)	Grey Iron Pipe(%)
C	3.5-4.0	0.1-0.2	3.2-3.8
Si	1.9-2.6	0.15-0.4	1.4-2.2
Mn	0.15-0.45	0.3-0.6	0.4-0.6
P	≤0.06	0.02-0.03	≤0.3
S	≤0.02	0.02-0.03	≤0.1
Mg	0.03-0.06		



## Metallographic structural test:



Metallographic structural test:  
Ferrite + little Pearlite

Grade of ductile iron  $\geq$  Grade Three

## Type of joint

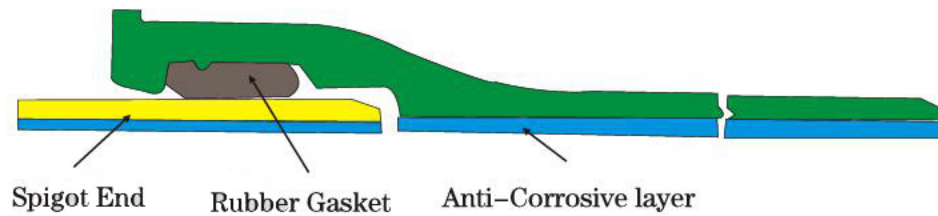

**Push-on Joint("T"Type)**

# ISO2531, EN545, EN598, BS4772

## TYTON PUSH-ON SOCKET SIZES

### Tyton Push-on Socket Sizes

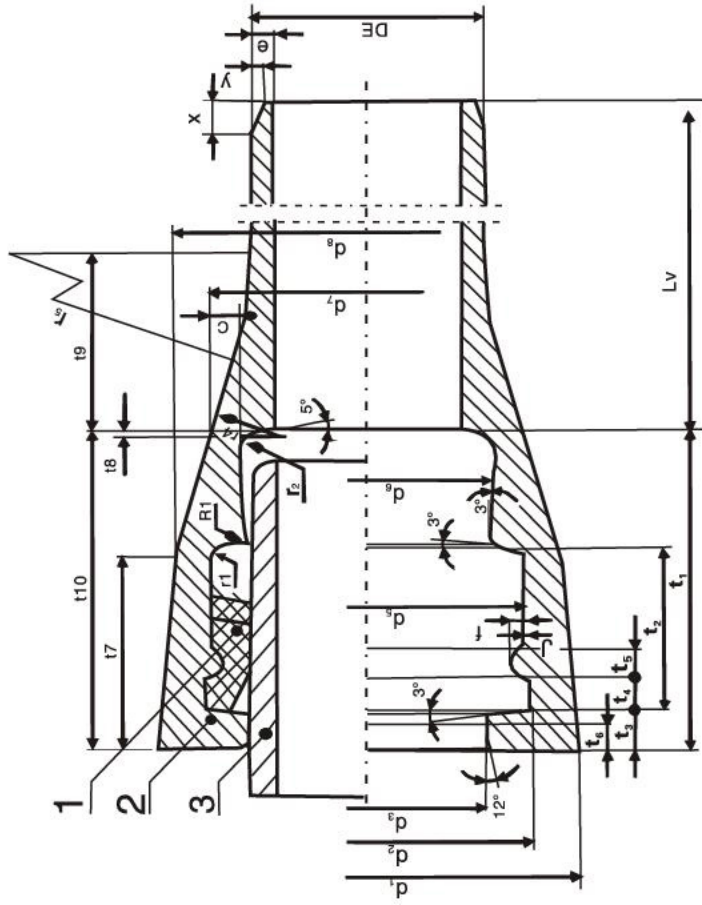

Type	1	2	3
T	Gasket	Socket	Spigot

DN80~1200 T type joint

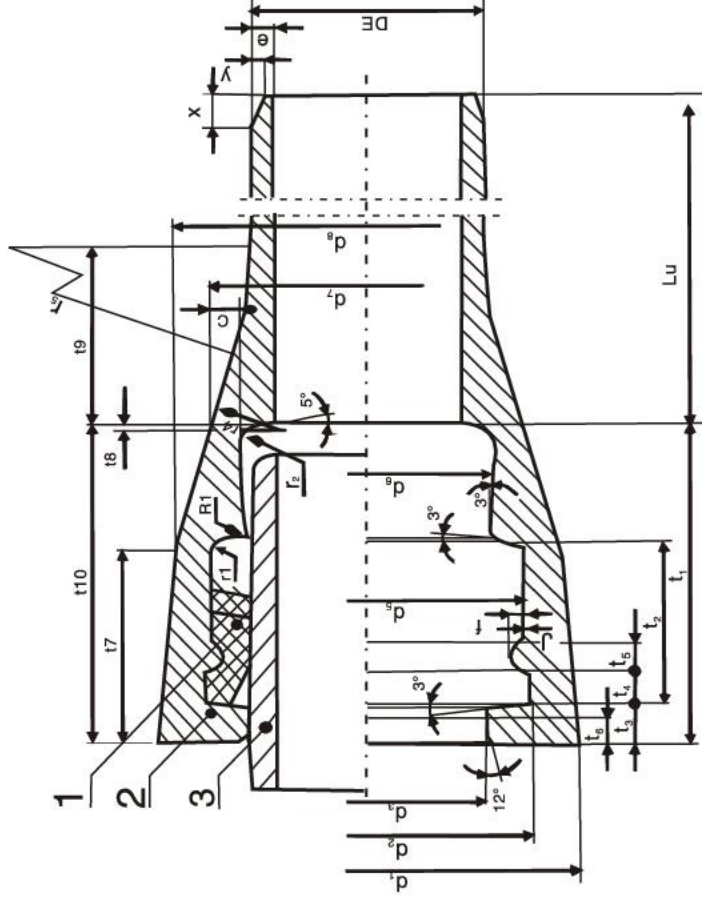

Type	1	2	3
T	Gasket	Socket	Spigot

DN1400~1800 T type joint

# ISO2531, EN545, EN598, BS4772

## TYTON PUSH-ON SOCKET SIZES

### Tyton Push-on Socket Sizes

DN mm	DE mm	d1 mm	d2 mm	d3 mm	d5 mm	d6 mm	d7 mm	d8 mm	c mm	f mm	t1 mm
80	+1 -2.8	140	123	100.5	±1	103.2	122	135	8	3.5	85
100	+1 -2.9	190	±1	120.5	±1	123.4	142	155.7	8.4	3.5	88
150	+1 -3.1	217	195	172.5	±2	175.3	195.6	209	9.1	3.5	94
200	+1 -3	278	250	224.5	+1.5 -1	227.8	251	265	9.8	4	100
250	+1 -3.1	336	301.5	276.5	+1.5 -1	279.7	305	323	10.5	4	105
300	+1 -3.3	393	356.5	328.5	+1.8 -1	332.1	368.5	384	11.2	4.5	110
350	+1 -3.4	448	408	380.5	+1.8 -1	383.8	410.3	433	11.9	4.5	110
400	+1 -3.5	500	462	431.5	+2.1 -1	435.8	463	482.4	12.6	5	110
450	+1 -3.6	540	514	482.5	+2.2 -1	487	518.4	533	13.3	5	120
500	+1 -3.8	604	568	534.5	+2.4 -1	539.4	569.7	590.6	14	5.5	120
600	+1 -4	713	673.4	637.5	+2.7 -1	642.6	676.7	698.8	15.4	6	120
700	+1 -4.2	824	788	740.5	+3.5 -1	745.8	789	813	16.8	7	150
800	+1 -4.5	943	894	844.5	+3.8 -1	850	892.2	922.3	18.2	8	160
900	+1 -4.8	1052	1000	947.5	+4.1 -1	953.2	999.2	1030.5	19.6	9	175
1000	+1 -5	1158	1105	1050.5	+4.4 -1	1056.4	1106	1139	21	9	185
1100	+1 -5.2	1267	1211	1155	+4.7 -1	1160.2	1213.5	1247.3	22.4	10	200
1200	+1 -5.5	1377	1317	1258	+5 -1	1264	1321	1355.6	23.8	10	215
1400	+1 -6	1610	1529	1465	+5.6 -1	1471	1535	1584.5	26.6	-	239
1600	+1 -6.5	1814	1740	1673	+6.2 -1	1678	1748	-	-	-	262

# ISO2531, EN545, EN598, BS4772

## TYTON PUSH-ON SOCKET SIZES

### Tyton Push-on Socket Sizes

DN mm	t2 mm	t3 mm	t4 mm	t5 mm	t6 mm	t7 mm	t8 mm	t9 mm	t10 mm	r1 mm	r2 mm	r4 mm	r5 mm	X	Y	Mass (kgs)
80	40	12	6	5	8	48	5	39	80	4	5	22	62	6	2	3.4
100	40	12	6	5	8	48	5	39	88	4	5	17	68	9	3	4.3
150	40	12	6	5	8	48	5	43	94	4	5	18.5	74	9	3	7.1
200	45	15	7	6	10	56	6.2	48	100	4	6	35	70	9	3	10.3
250	47	15	7	6	10	58	6.8	48	105	4	6	36	72	9	3	14.2
300	50	17	8.5	7	12	61	7.2	56	110	6	7	37	74	9	3	18.6
350	50	17	8.5	7	12	61	5.1	55	113	6	7	24.5	98	9	3	23.7
400	55	19	9.5	8	14	68	5.1	58	116	6	8	26	104	9	3	29.3
450	55	19	9.5	8	15	68	6	66	120	6	8	28	105	9	3	38.3
500	60	21	11	9	16	75	7	63	120	6	10	29	116	9	3	42.8
600	65	21	12	10	16	80	9.2	62	120	6	10	32	128	9	3	59.3
700	80	21	18	12	16	90	10.6	77	150	8	10	35	140	15	5	79.1
800	85	21	18	14	16	96.5	12.4	86.5	160	8	10	38	160	15	5	102.6
900	90	21	20	16	16	103	14.2	92.5	175	8	10	42	175	15	5	129.9
1000	95	22	20	16	16	110	16	103	185	8	10	45	200	15	5	161.3
1100	100	24	23	18	16	116	17	107.5	200	10	12	46.5	207.5	15	5	194.7
1200	105	25	23	18	17	122	17.8	112	215	10	12	48	215	15	5	237.7
1400	115	27	25	-	18	125	19	119	239	10	12	100	205	20	7	279.3
1600	125	30	27		20	125	19	165	262	10	10	380	210	21	7	375.4

Nominal Size DN	Barrel			Socket mass (approximate)	Preferred pipe pressure classes	Total mass (approximate) for one working length L of	
	DE	e	Mass per metre (approximate)			5.7m	6m
DN80	98	4.4	9.1	3.4	C40	55	58
DN100	118	4.4	11.1	4.3	C40	68	71
DN125	144	4.5	14.1	5.7	C40	86	90
DN150	170	4.5	16.5	7.1	C40	101	106
DN200	222	4.7	22.6	10.3	C40	139	146
DN250	274	5.5	32.6	14.2	C40	200	210
DN300	326	6.2	43.9	18.6	C40	269	282
DN350	378	6.3	51.9	23.7	C30	319	335
DN400	429	6.5	60.8	29.3	C30	376	394
DN450	480	6.9	72.3	38.3	C30	450	472
DN500	532	7.5	87.0	42.8	C30	539	565
DN600	635	8.7	120.6	59.3	C30	747	783
DN700	738	8.6	142.0	79.1	C25	888	931
DN800	842	9.6	176.9	102.6	C25	1111	1164

## **Production process flow of ductile iron pipes Advance quality testing system**

### **Metal preparation**

Molten metal can be obtained directly by reduction of iron ore in a blast furnace, or by melting pig iron and scrap in a cupola(or electric furnace), in all cases the materials have to be selected and checked carefully, in order to produce a very high purity base metal suitable for the treatment described below.

After desulfurization, the iron temperature is adjusted in an electric furnace, to provide the optimum casting temperature. At this stage, corrections can be made to the chemical composition by additions of scrap metal of specific ferro-alloys. Magnesium is introduced into the molten metal, to render it ductile.

### **Foundry casting**

The pipe spinning process consists of deposition of a layer of molten iron inside a rapidly rotating cylindrical mold, and solidification of the metal by continuous mold cooling.

The principal methods used are the "de LAVAUD" process and the "WET SPRAY" process.

In the "de LAVAUD" process, molten metal is poured into an uncoated steel mold and is subjected to rapid cooling. A graphitizing, then ferritizing heat treatment is necessary to obtain pipes with the required structure and mechanical properties.

In the "WET SPRAY" process, before the iron is poured, the internal surface of the mold is coated with a fine layer of powdered refractory silica, which reduces the thermal conductivity of the molten metal/mold interface. The pipe therefore cools at a slower rate than in the "de LAVAUD" process and consequently only a ferritizing heat treatment is required.

## Finishing/Coating

On leaving the heat treatment furnace, the pipes receive an external coat of pure metallic zinc, applied by electric arc melting of zinc wire and spraying with compressed air.

Many types of inspection and tests to guarantee quality are carried out: metallography, checking the structure, mechanical properties of the metal, visual inspection, dimensional checks, individual hydrostatic test. Particular attention is paid to spigots and sockets because they are important in joint sealing.

The mortar lining is centrifugally applied. The mortar is poured into the pipe and then spun at high speed, which has the effect of giving the lining good compaction.

The cement mortar is then cured under controlled temperature and humidity conditions.

After the mortar has cured, the pipes move on to the coating lines. A layer of bituminous paint is then applied by spraying on top of the zinc.

The pipes are then bundled (DN ≤ 300) and put into stock to wait for dispatching.

**Please check the following process flow diagram:**

**Process flow diagram**

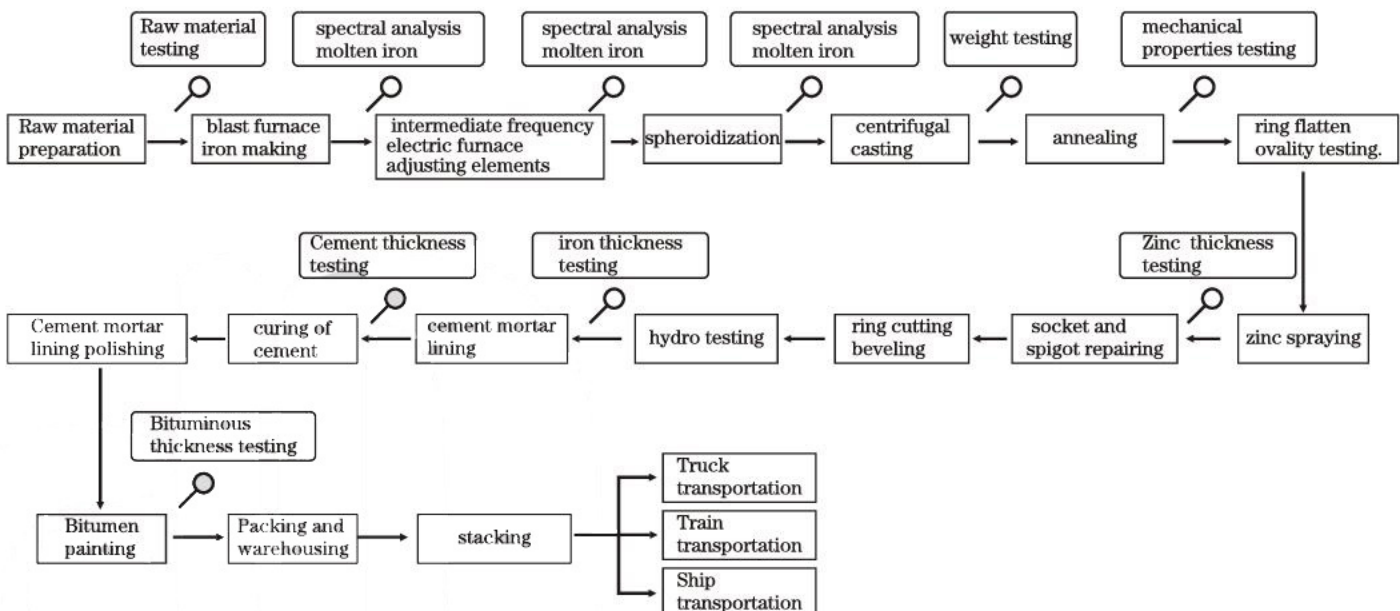

## Raw material preparation



Raw material testing : Testing Silicon, manganese, phosphor & etc.



## Blast furnace iron making

The requirement of melt iron:

There is strict requirement for the composition & temperature of melt iron. The temperature of melt iron is above 1400℃, the percentage of surfur is up to 0.01% to 0.025% after desulfurize.





## Spectral analysis

Analyzing C, Si, S, P, Mn, Mg, Ti & microelement which are about 20 elements according to properties of melt iron.



## Sampling

It should be sampled under 200mm of melt iron surface from ladle.

It should be sampled on 1/2 place between the middle of melt iron surface and wall ladle.

Spectral analysis after sampled again.

## Spheroidization



## Core making



## Centrifugal casting



## Pulling pipe



## Annealing

It need annealing under high temperature for ductile iron pipe made by water cooling centrifugal casting which is 920-950°C.



## Mechanical performance test



Ring pressed test



Impact test

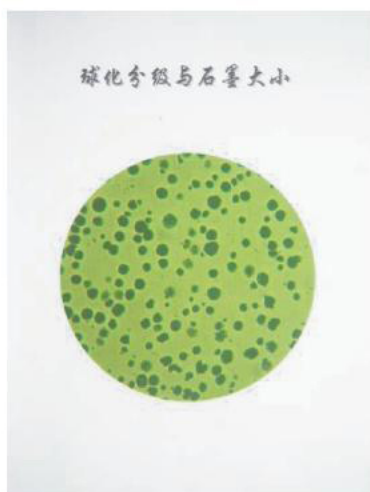

Metallography

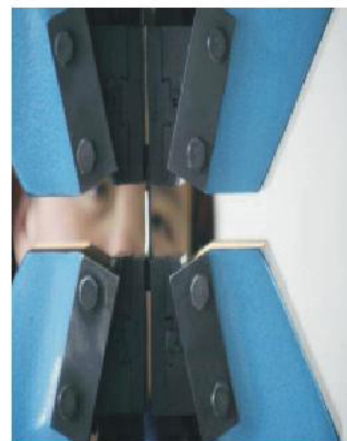

Tensile test

## Zinc spraying

According to ISO8179 standard

- Coating with metallic zinc which contains zinc at least 99.99%.
- The average mass for zinc coating is not less than 130g/m<sup>2</sup>, the mass of zinc coating for any point should not be less than 110 g/m<sup>2</sup>.

A rectangular token of known weight per unit area shall be attached longitudinally along the axis of the pipe before passing it through the coating equipment. After zinc coating and trimming, the size of the token shall be 500mm x 50mm. it shall be weighted on a scale having an error limit ± 0.01g. The mean mass M of zinc per unit area shall be determined from the mass difference before and after coating.

$$M = \frac{C (M_2 - M_1)}{A}$$

Where:

M is the mean mass of zinc in grammes per square meter;

M<sub>1</sub> and M<sub>2</sub> are the masses of the sample token, in grammes, before and after coating;

C is the predetermined correction factor, taking account of the nature of the token and of the difference in surface roughness between the token and the iron pipe; A is the actual area of the trimmed token, in square metres.

NOTE: The value of C, generally lying between 1 and 1.2, is given in the manufacturer's quality assurance plan.

The uniformity of the coating shall be checked by visual inspection of the token; in the event of a lack of uniformity, 50mm x 50mm pieces shall be cut from the token in the lighter mass zones and the mean mass of zinc determined on each piece by mass difference.

Alternatively the mass of zinc per unit area can be measured directly on the coated pipe by any method having proven correlation with the reference method described above, e.g. X-ray fluorescence or chemical analysis.



### Weight of zinc coating measured



### Socket and spigot polishing



Each pipe's socket (inside diameter) and spigot is controlled by a regularly calibrated gauge.

### Hydro test

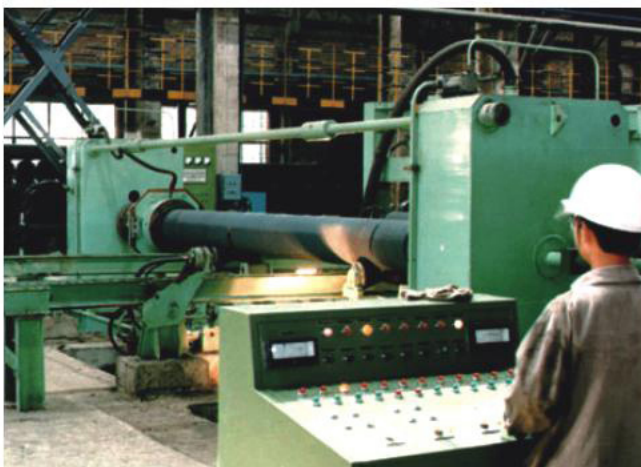

### Wall thickness measured



## **Cement mortar lining**

### **Acc to ISO4179 standard**

#### **Surface preparation:**

All surfaces to be mortar lined should be cleaned of dirt, loose rust particles, grease, oil or any other material which could interfere with the adherence of the cement mortar or protrude through the lining.

#### **Lining equipment and process:**

Water used for the mortar shall be of potable water quality and shall not contain elements which influence the hardening of the lining or the quality of the water flowing through the finished pipes.

Mortar for the lining shall be composed of cement, sand and water. The mortar shall be well mixed and of proper consistency to produce a dense homogenous lining that will adhere firmly to the DI pipe surface. Weight of cement and sand shall be accurate to + 3%. The water/cement ratio shall not be more than 0.4. The cement mortar shall not contain less than one part of cement to 3.5 parts of aggregates by weight as per ISO 4179.

Linings will be manufactured using centrifugal pipe rotational equipment which sustains high-speed acceleration on the applied lining. The mortar of the lining is cast centrifugally inside the pipe. Grinding of linings will not be allowed. The minimum centrifugal force for application of the lining is 45 G for 400mm and smaller and 60 G for 450mm and larger. Simultaneous controlled vibration shall be applied to the pipe during high-speed rotation to produce a lining of such high density and firm compaction that it will immediately allow laitance washing with a large volume of water. The mortar shall be mixed in batches. The amount of cement and sand entering into each batch shall be measured by weight. The quantity of mixing water entering into each batch shall be measured automatically by an adjustable device, or it shall be otherwise measured to ensure that the correct quantity of water is being added. The lining shall be uniform and extend from the spigot end up to the beginning of the socket cavity on the other side. The socket shall be left free of mortar.

### Washing and finish:

After the mortar has been distributed, the rotational speed and vibration shall be increased to produce a mortar lining with a uniformly smooth, firm surface.

Immediately after lining, the surface of the lining shall be washed with water to remove excess laitance.

Cement lining thicknesses shall be per ISO 4179 and as shown in the table below. For 450mm and larger pipe, the exposed edges of the lining are essentially square and perpendicular with the axis of the pipe.

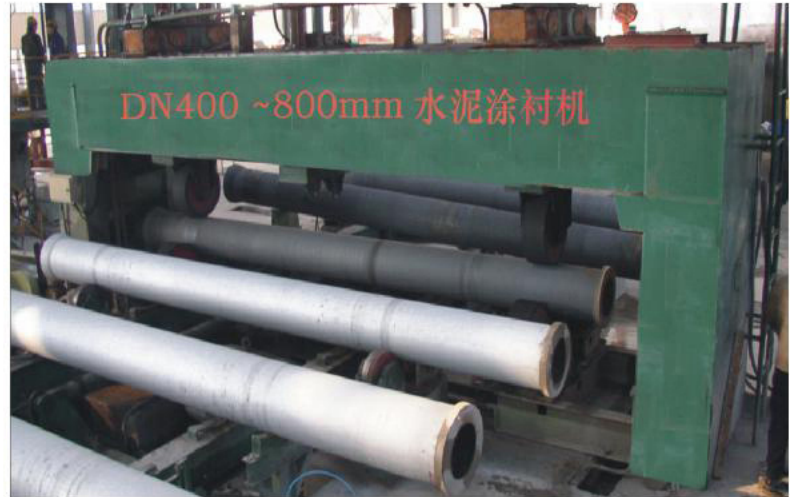

Pipe Size	Nominal Lining Mean Minimum Thickness (mm)	Mean Minimum Thickness (mm)	Minimum Value at One Point
80mm – 300mm	3.0	2.5	1.5
350mm – 600mm	5.0	4.5	2.5
700mm – 1200mm	6.0	5.5	3.0
1400mm – 1800mm	9.0	8.0	4.0

NOTE: For some service conditions, greater lining thicknesses also can be provided.

## Curing of cement

Cement mortar linings shall be adequately cured in a facility with controlled atmosphere. Linings shall be furnished standard without seal coat.

The pipes should be put in drying pool after 15 minutes stayed in air which is steam press  $\geq 0.1\text{MPa}$ , temperature  $> 30^{\circ}\text{C}-55^{\circ}\text{C}$ , humidity  $\geq 85\%$ , time  $> 8\text{hours}$ .



## Cement mortar lining polishing





## Bitumen painting

Ductile Iron pipe shall be externally coated with a black bituminous paint with a mean dry film thickness of not less than 70 microns with a local minimum thickness of 50 microns acc to ISO8179 standard. The coating shall be smooth, neither brittle when cold nor sticky when exposed to the sun, and shall be strongly adherent to the pipe. The detailed step is as following:

- a. Before painting: remove dirt of socket and then brush with semi-gloss, innocuity, quickly drying, red high build anti-corrosive paint (guarantee appearance quality, gloss, corrosion resistance, staying quality).
- b. Warm up the pipe to a temperature of 70–80°C and paint with high build bituminous anti-corrosive paint.
- c. Entering into dry furnace to dry quickly in a temperature of 60–70°C.

The dry film thickness of paint coatings shall be measured by any of the three following methods:

- directly on the casting by means of suitable gauges, e.g. magnetic, or by using a 'wet film' thickness gauge where a correlation between wet film thickness and dry film thickness can be demonstrated;
- indirectly on a token which is attached to the casting before coating and is used after coating to measure the dry film thickness by mechanical means, e.g. micrometer, or by a weight method similar to weight of zinc coating measured;
- indirectly on a test plate made of steel or of ductile iron, which is coated by the same process as the castings to be controlled.

For each casting to be controlled, at least three measurements shall be taken (either on the casting or on the token or on a test plate). The mean thickness is the average of all the measurements taken and the local minimum thickness is the lowest value of all the measurements taken.



## Drying

The bitumen coating will be dry quickly under 60–70°C when they are put in drying equipment.

## Visual inspection and dimensional test:

Pipes shall have adequate visual inspection of external coating and internal lining surfaces and adequate measurements of wall thicknesses, spigot outside diameters, socket inside diameters, and other product dimensions to insure that the products furnished meet project specifications.

## Storage and lying instruction



## Pipe storage

### General Recommendation

- 1.The storage area must be flat, the ground must not be marshy or unstable and it must not contain any corrosive material.
- 2.On arrival in storage area the goods must be inspected and if there is any damage (degradation of the internal or external coating), it must be repaired before going into the stock.
- 3.The pipes must be stocked in the respective stakes according to diameter in accordance with a logical stock plan.
- 4.It is always desirable to protect coating from the effects of weathering and prolonged exposure to the sun.
- 5.Use shaped hooks covered with special protection of plastic material or rubber, to avoid any damages to the internal coating of the pipes.
- 6.Wooden spacers (timbers, wedges, etc) must be strong enough and of good quality.

### Bundling of Pipes

DN  $\leq$  300 Pipes are bundled and protected with steel belts on both socket and spigot.

DN > 300 Pipes are not bundled.

### Stacking Arrangement

Pipe can be stacked in one of the three cases shown here:



Case1



Case2



Case3

#### **Pyramid stack, socket to spigot (Case 1)**

In practice, this is the method of most interest from the point of view of safety, cost of supporting materials and the ratio of the number of pipes stored to stack volume.

This method, however, necessitates end-lifting by means of hooks ; use of multiple hooks allows lifting of several pipes simultaneously.

**Bottom layer:** the bottom layer is laid on two timbers, arranged in parallel, one being 1m from the socket end and the other 1m from the spigot end. The pipes are also parallel with one another. The socket can touch and are not in contact with the ground. The pipes at the two ends are secured at the sockets and spigots with large wooden wedges nailed to the timbers. The intermediate pipes are only secured at the spigot end, using smaller wedges.

**Upper layers:** the upper layers consist of pipes laid alternately socket to spigot, with all the sockets in one tier overhanging the spigot ends of the tier below, by the length of the socket plus 10cm (to prevent spigot deformation). The barrels of two consecutive tiers are in contact.

#### **Uniform stack, sockets at same end (Case 2)**

**Bottom layer:** the bottom layer is identical to the case 1.

**Upper layers:** the pipes are in line vertically. Each tier is separated by timbers slightly thicker than the difference in diameter (socket-barrel).

The ends of pipes in each tier are secured by wedges nailed to the timbers. This method allows all type of lifting (end-hooks, slings around the barrels, forklift trucks).

#### **Square stacks (Case 3)**

**Bottom layer:** laying and wedging of the bottom layer is identical to the case 1, but the pipes are sockets to spigots; their barrels are in contact. In addition, the sockets project beyond the spigots of adjacent pipes by the whole socket length, plus 5cm. For  $DN \geq 150$  pipes stacking is on three timbers (instead of 2).

**Upper layers:** each tier consists of parallel pipes laid socket to spigot, as in the bottom layer. The pipes in one tier run at right angles to those in the tier below. The pipes ends are consequently wedged naturally by the alternating sockets in the tier below. This method keeps the packing material to a minimum, but involves individual lifting of pipes because of the stack formation. It is strongly recommended, however it should not be used for pipes with special coatings, in view of the type of support (point contacts).

The pipes with cement mortar lining should be stacked in limited layer, allowed layers and pieces as following:

Maximum number of layers as a function of stack formation													
DN	80	100	150	200	250	300	350	400	450	500	600	700	800
Case 1	70	58	40	31	25	21	18	16	14	12	10	7	6
Case 2&3	30	27	22	18	16	14	12	11	10	8	7	5	4

### Storage of rubber ring and notice

As in ISO4633: Mainly the ring shall be stored in accordance with the following precautionary measures:

- 1.Storage temperature should be below 25℃ and preferably below 15℃.
- 2.Elastomer rubber should be protected from light, direct sun light and strong artificial light with a high ultraviolet content.
- 3.As ozone is particularly deleterious, storage room should not contain any equipment which is capable of generating ozone such as mercury vapour lamps, high voltage electrical equipment, electric motors or other equipments which may cause electric sparks or silent electrical discharge.
- 4.Elastomer rubber should be stored in a normal position that is free from tension, compression and other deformation. Meanwhile it is necessary to reduce stocking time as far as possible.



## Lifting, Transportation of ductile iron pipes

### Pipe lifting

#### 1. End lifting

Use appropriately shaped hooks, coated with a polyamide type protection.

#### 2. Barrel lifting

Use wide flat slings maintained sufficiently widely apart to prevent accidental slippage. Prohibit wire ropes which may damage the coating.

A single sling may be used on site. In that case, lift the pipe at its centre of gravity, with the sling gripping the pipe to prevent slippage.

#### 3. Bundle lifting

DN80 to 300 bundles are unloaded with flat textile slings.

Take precaution of handling with steel cable, hoisting belts and specialized rigging avoiding from pipe's rock. While using steel cable, single cable is not admitted, for the purpose of protecting outer anti-corrosion layer, steel cable should be packed by rubber or other similar material. While using hook, it also should be covered with rubber or other similar material for protecting cement lining layer. Especially for pipe with relative large diameter, hook should be mounted a gasket with same shape as internal diameter of pipes while handing. It is not available fixing hook on the steel belts or socket side and spigot side of pipe while handling pipes in bundle.

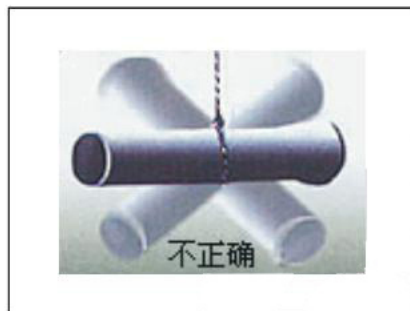



Vehicles must be suitable for transporting, loading and unloading ductile iron pipes. The following basic rules must be observed:

- 1.Prevent any contact between the pipeline components and metal surfaces (to avoid coating damage).
- 2.Prevent any direct pipe connecting with the bottom of the trailer (keep the pipes horizontal with two parallel rows of good quality timbers fastened to the floor).
- 3.Facilitate pipe loading and unloading under safe conditions (use textile slings or protected hooks; do not use wire ropes).
- 4.Ensure the load is in good order during transport.
- 5.Use vehicles and trailers equipped with side supports to stabilize the load (adequately sized stanchions on either side of the floor).
- 6.Secure the load with textile straps and a tautening device.

## **Installation guide**

1. Using a wire brush and a rag, carefully clear the inside of the socket particularly the gasket recesses. In particular, remove any deposits of earth, sand, etc. also clean the spigot of the pipe to be jointed and the gasket itself. Check the presence of the chamfer, as well as the absence of any damage on the spigot of the pipe. (See picture 1 & 2)
2. For ductile iron pipe typed DN100~300mm, insert folded gasket into the socket end to make brake facing block embed tightly in the base. Press the protrude of gasket till the gasket fixed evenly in the socket. For pipe typed above DN400mm, bend two ends of the gasket, then press two protrudes outwards one by one, thus more easily insert the gasket into the base. The internal face of brake facing block can't be extend from the brake of the socket. (See picture 3)
3. Lubricate interface of gasket and spigot end. Lubrication could be soap water or nonpoisonous alkaline lubrication. (See picture 4&5)
4. Insert spigot into socket till touch gasket at the same axle. It must be straightened properly to make the central axle of pipes or fittings coincide. While connecting pipe, different pipe adopts different tools. Insert pipe carefully and continuously, if existing larger resistance force, pipe connection should be stopped immediately then draw out the pipe and check the position of rubber gasket and socket and spigot end. After removing troubles, insert again. The insert depth required should be between two white lines.(See picture 6)

5. Check that the gasket is correctly in position by inserting the end of a metal ruler through the annular spigot and socket gap until it touches the gasket. The ruler must penetrate to the same depth around the whole circumference.

6. After finish assembling joint, make sure that the curvature after assemble does not exceed the permissible angular deflection of particular joint. See the table.

DN ( mm )	Permissible angular deflection while laying
80-150	5° 00'
200-300	4° 00'
350-600	3° 00'
700-800	2° 00'
900-1800	1° 30'

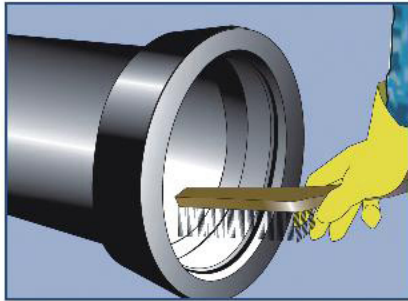

Picture 1



Picture 2

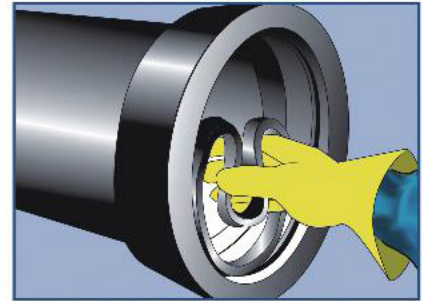

Picture 3



Picture 4

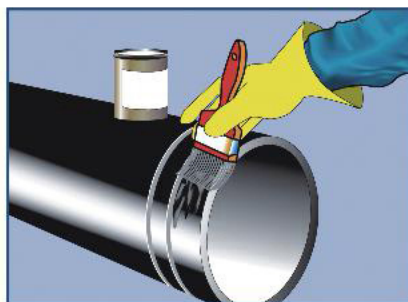

Picture 5

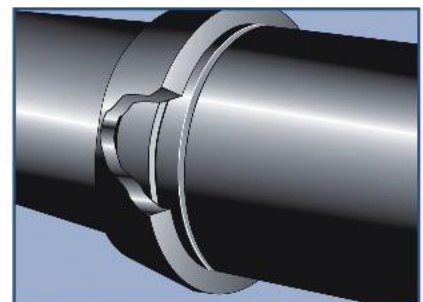

Picture 6



## Repair soft damage of ductile iron pipe

Cut some part of pipe because of construction requirements or ellipse on the spigot end occurring for unsuitable handle during transporting, or less damage of internal and external lining pipe.

### 1. Pipe rounding:

Through hydraulic or mechanical hoisting way, withstanding internal wall and pressing outwards, or withstanding external wall and pressing inwards for avoiding damage cement lining, hardwood gasket should be used similar with internal shape of pipe.

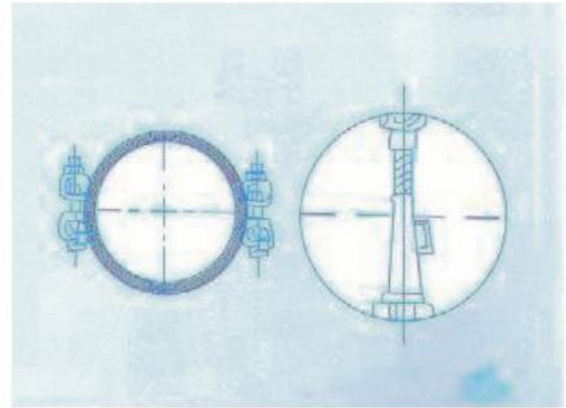

### 2. Pipe cutting:

Pipe cutter can be mounted grinding wheel for cutting and polishing. Emery wheel is suitable for cutting pipe with cement lining. Pipe should be laid the ground or rectangle wood while cutting. Steps of pipe cutting: marking, cutting, and polishing.

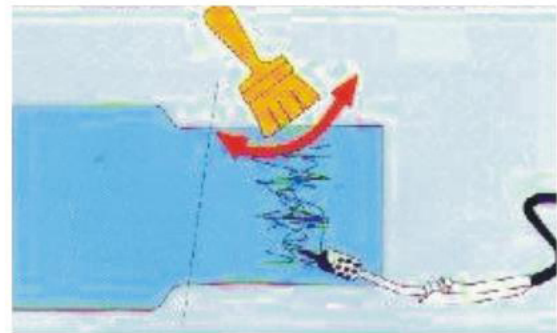

### 3. Repair outside coating layer:

Clean the surface with furry brush or wire brush, if necessary, it can be dried with natural gas. After cleaning, coat with oil paint.

### 4. Repair cement lining

- a. Turn the parts needed repairing to the bottom and get rid of the damaged part.
- b. Remove residual cement with wire brush and moist the cement layer edge which needs repairing, and then waiting for several minutes.
- c. Filling cement mortar and press it to the original thickness of cement layer.
- d. Finally coating the surface smoothly and add some water or cover a layer of washed cloth on it to avoid cement dry immediately and produce cracks.

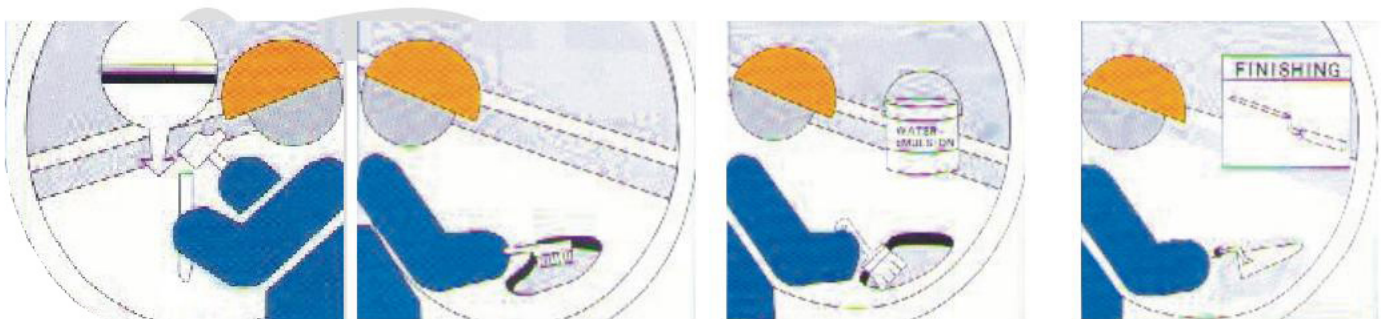



ADD : 28th, Huanqiu Jinrong Zhongxin, Xieyuan Road,  
Changfeng Business District, Taiyuan , Shanxi, China

Postcode : 030021

TEL : 0086-351-6814868

FAX : 0086-351-8390339

Email : [info@mds-group.cn](mailto:info@mds-group.cn)

Website : [Http://www.sxmidas.com](http://www.sxmidas.com)